



INSIGHT software



Operating instructions

INSIGHT user manual

v3.00
Part No:
SU6045



PLEASE NOTE THAT CROSBY|STRAIGHTPOINT ACCEPT NO RESPONSIBILITY FOR ANY ERRORS OR OMISSIONS WITHIN THIS MANUAL.

Before Use	5
Overview	5
Prerequisites	5
Computer System Requirements	5
Installation	5
USB Dongle	6
Running INSIGHT	7
Activating INSIGHT	8
Configuring Load Cells	9-10
Setting up a Project	11-12
Project Name and description	11
Units	11
Logging Type (<i>select option from the drop down list</i>)	12
Logging Interval (<i>ms</i>)	12
Logging Directory	12
RF Channel and Security Key	12
Overload %	12
Project Load Cells	13-17
Edit Project Load Cell	13
Load Cell Serial Number	14
Formula	14
Description	15
Alarm Settings	15-16
Advanced Settings	16
Load Cell Displays	18-19
Load Cell Display Icons	20
Load Cell Charts	21
Visualisations	22
Reports	23-24

Centre of Gravity (CoG)	25-27
Proof Test Plus (PTP)	28
PTP Set-up	29-34
Set-up	29
Set up engineers	30
Select load cells	31-32
Set up customer	33
Set up load test	34
Using the System	35-38
Testing	35-36
Test Reports/Certificates	37-38
Database management	39
Data Logging	40
Logged Data File format	40
Backup and Restore Functions	40
Glossary of Icons	41
Glossary	42
Notes	43

Before Use

Overview

The functions of the INSIGHT software package are as follows:

- To act in a similar capacity to a hand held display.
- To chart, log and report load cell data readings.
- To produce and display a visualisation of the working set-up.
- To calculate and produce Centre of Gravity (COG) Reports.
- To do proof testing and generate certificates where traceability and documentary evidence is required of load verification and proof testing.

Prerequisites

To use the INSIGHT Software, you will require a USB dongle (SW-D) and at least one TS load cell.

Computer system requirements

- Processor: 3 gigahertz (GHz) or faster
RAM: 4 GB
With .NET 4.5.2 or above (should be automatically installed)
- Windows® 7, Windows® 8 or Windows® 10 or Windows® 11
(must have English language option selected)
- Spare USB port (not hub)

Installation

To start, either:

Scan the QR code found on the card that accompanies the SW-D USB dongle to download software to your phone and then, when the download is complete, transfer the file to your PC online or offline.

Or

Type in the web link address into your web browser's address bar to download software directly to your PC.

www.straightpoint.com/software/insight.zip

Once the download has completed, please double click on the downloaded file and the software should auto install.

Your version of Windows may inform you that this INSIGHT Software may harm your PC and ask permission to install it, in which case take the path to install the software.

USB Dongle

Plug the USB dongle into the PC, no driver needs to be installed.



To achieve a better line of sight between the USB dongle and the load cell you can attach it to a sports/action camera (e.g. Go-pro) mount and clamp kit.

You can then connect dongle to PC via a USB extension cable.

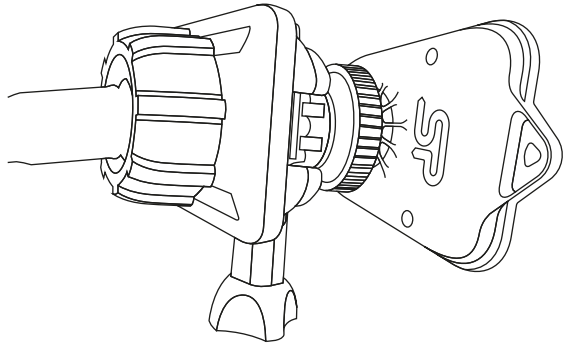

Setup dongle with mount kit so that direct line of sight between the dongle and the load cell is achieved.

Note: If you have load cells which are on more than one RF channel, multiple dongles can be used.

Allocation of the channel associated with a dongle is automatic.

Note: The load cell is normally factory set to a single channel 15.

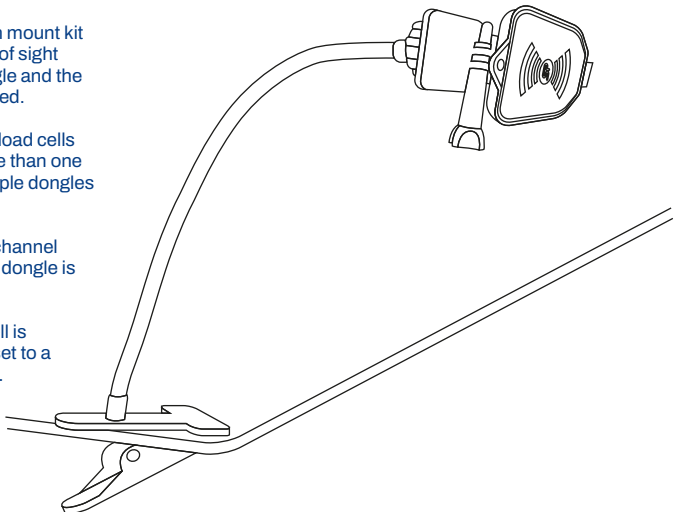

Running INSIGHT



Either locate the INSIGHT icon or type 'INSIGHT' into the Windows search bar and then double click on the INSIGHT icon to run it.

The following screen should appear briefly (see below).
If INSIGHT needs to be activated, see 'Activating INSIGHT' on page 8.



The screen above is then followed by:



Note: If the USB dongle has been correctly inserted, the screen should show 'USB Connected' in amber at the bottom.

Activating INSIGHT

IMPORTANT: In order to operate INSIGHT, it needs to be activated.

There are two means of activation (1) Online and (2) via a Licence Key. Normally the online method would be used.



Online Activation

For the online method fill out the details in the screen and click Activate.

This will send a message through to the Crosby Straightpoint server, notifying us. When your details have been checked, the activation will be approved, the screen will close and enable you to proceed to use the INSIGHT software.

N.B. The checking process may take several days, so please activate well in advance of needing to use the software.



Activation Key

This allows use of the Insight software offline. It will need to be re activated on an annual basis.

Select the option to enter a licence key and the following screen will show.

Email Crosby Straightpoint: activate.sp@kitocrosby.com quoting the unique ID (in this case 1080D163) with your email address and company details. You will then be emailed and provided with a code to enter into the licence key, once this code is entered click 'Activate' and the message will be removed and progress into the INSIGHT software.

Configuring Load Cells

Before the functionality and features of INSIGHT can be used, a data base of load cells needs to be created in order to make them available for the software to use.

You must have at least one Crosby Straightpoint TS load cell available for use.



Select the load cell data base icon in the top left corner of the INSIGHT screen.

Assuming your load cell(s) are powered on (batteries are inserted), select the 'Scan' button towards the top right-hand corner (highlighted above).

If your RF channel or Security key is different to that displayed in the 'RF Channel' drop down options, these will need to be correctly set before the scan can start. If they are not set to the correct channel or key, your load cell will not be displayed. Default load cell channel is 15.



Configuring Load Cells (contd.)

Once the scan is initiated, the load cells that are available will appear in the load cell data base window within a minute.

Once the load cells have appeared in the window, select the **'Stop'** button (highlighted below) to terminate the scan.



If you do not click the **'Stop'** button you will not be able to edit any other item.

To highlight any entry, please click on it. If you would like to remove any load cell from the data base, highlight it and then select the **'Remove'** button.

If the load cells are not showing, they can be added manually by selecting the **'Add'** button. To do so, select the new blank entry and add information for every field, apart from the version number. The data will be automatically saved and the **'Saved load cell'** message will appear while you type in the information.

You can go back to the load cell data base option and add further load cells, if required.

You should now have added the load cell(s) you require to the data base and can now explore the other functionalities of the INSIGHT software.

Note: One dongle will operate on one or more load cell(s) with the same channel and security key. If you have load cells with different security keys or on different channels then to use these at the same time within the same project you require an additional dongle.

To use these additional dongle(s) repeat the scan process above, changing the RF channel and security key as required.

Setting up a Project

Once the load cell database has been populated, the next stage is to create a project. This needs to be performed before accessing any other functionality such as load cell data display, COG(Centre Of Gravity) calculation or Proof Test Plus. Creating a project assigns one or more of the load cells from the load cell data base to the project.

If the project already exists, then you can select the 'Projects' folder (shown below) and then select 'Project' folder symbol to display a list of projects in a window; you can then select one project by clicking on it. The project details can then be edited if required.

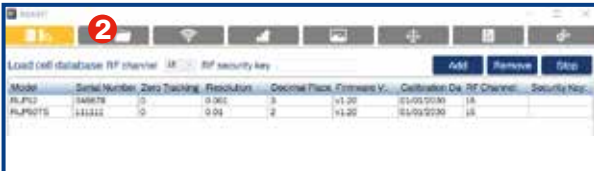

To start a new project click, '+New' (highlighted below) — this must be done before any data fields are entered.

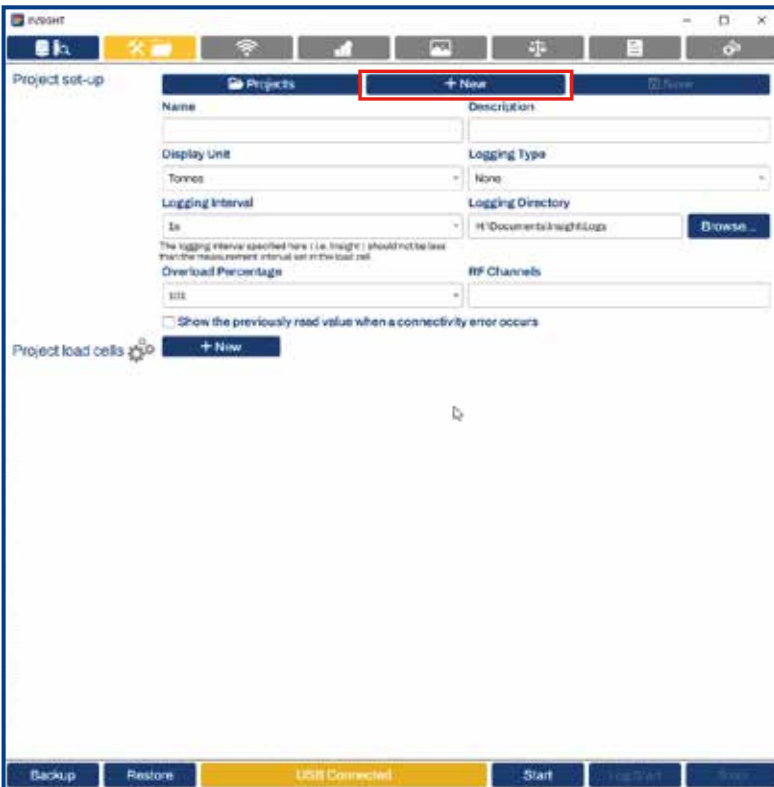

Once '+New' is clicked, please enter the following information:

Project Name and description

Provide a project name ('Name') and description ('Description') as plain text.

Units

Select the project units from the drop down box for either Tonnes / Kilograms / Kilo Newtons / Pounds ('Display unit descriptions'), these units supersede the units shown in the load cell database.

Setting up a Project (contd.)

Logging Type (select option from the drop-down list)

- 'None'
No logging will be performed, and no log data files will be created.
- 'Continuous'
All data from the load cell(s) will be logged to the data file at the Logging Interval. Logging must be initiated by clicking the '**Log Start**' button.
- 'Manually Triggered'
Single data values will only be logged to the file if the '**Log**' button is clicked.
- 'At Alarm'
The data value which first exceeded an alarm condition will be logged to the data file. Logging must be initiated by clicking the '**Log Start**' button.
- 'While In Alarm'
Data values are logged to the data file while the stated alarm conditions are exceeded. Logging must be initiated by clicking the '**Log Start**' button.

Logging Interval

Enter the interval you want the data logged at to the data files. This overwrites the measurement interval selected for the load cell. You should not select a logging interval which is at a greater resolution than the load cell measurement interval.

Some logging intervals are in milliseconds; hence a value of 1000ms is one second.

Logging Directory

Enter the directory path where the data files are to be stored. This path is also used for the COG report.

Note: The default path is linked to the user's profile and is normally:-
'C:\Users\YourName\Documents\Insight\Logs — It may have been mapped differently on your network.

RF Channels

By default, the system uses RF channel 15 and the security key field is left empty. These values are ported across from the first load cell that was added to the project and are therefore not editable.

Overload percentage

This is the percentage of the load cells' WLL. If that percentage is exceeded, the text '**OVERLOAD**' is displayed instead of the data load value. By default, the value is set to 101. Set to 0 (zero) to turn off this feature.

Please make sure you select the '**Save**' button before moving onto other displays (highlighted below).



- 1 Show the previously read value when a connectivity error occurs**
Tick this checkbox to show the current value displayed when a communication timeout error occurs with a load cell.
If it is not checked, and a time out error occurs, dashes will be displayed. This helps when many load cells are connected and timeout error can occur temporarily (highlighted).
- 2** Please make sure you select the '**Save**' button before moving onto other displays (highlighted).

Project Load Cells

Load cells from the data base must now be associated with a project. This is done by selecting the Project Load Cells '+New' button

Further load cells can be added via the '+New' button, once the information for one load cell is entered and saved.



A window, entitled 'Edit Project Load Cell' will then appear.

Edit Project Load Cell

Within this screen you can select a load cell for the project or use a formula based on a load cell. You can also set up alarms, COG details and other settings.

Please make sure you select the 'Save' button before moving onto other displays.

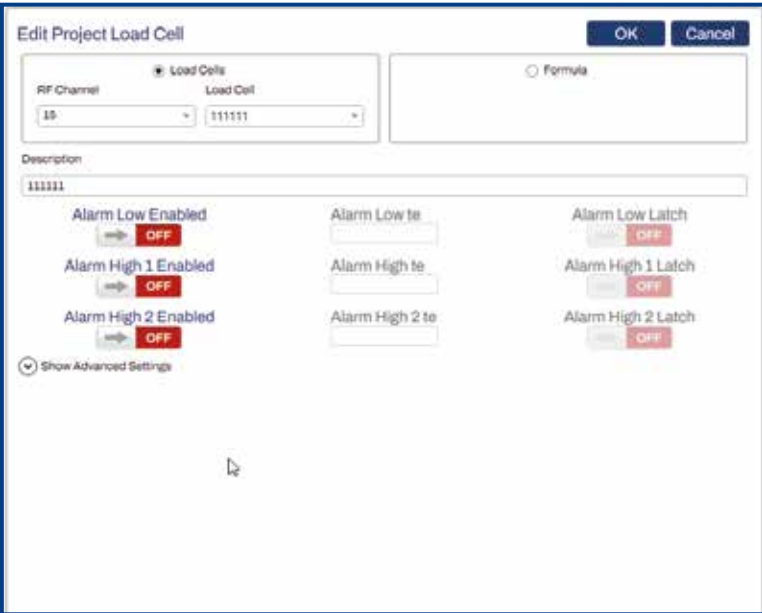

Project Load Cells (contd.)

Load Cell Serial Number

For uses such as displaying load cell data. It is likely the load cell serial number is the only field you will need to visit and use. This option associates a load cell with a project for data display or COG calculation. The load cells added to the project will also list in the Proof Test section, so the user can select the required load cell from that list and can use for Proof Test applications.

The radio button defaults to 'Load Cell Serial Number' but if it is moved to formula then reselect it on the Load Cell Serial Number.

Selecting the drop-down field within the load cell serial number option will show a list of serial numbers from the load cell data base. Select one of these load cells from the drop-down list to use within the project. This will associate this load cell with the project for use in displaying the load cell data and using it in the COG calculation.

The description field defaults to the same as the load cell serial number, however, any text string can be entered here.

Formula

Instead of using the load cell's data readings directly (as shown on the previous page), a formula based on the load cell data readings can be used. This can be useful if custom units with a conversion factor are required, or the sum of several load cells is required.

The load cell to use in the formula can either be entered directly with its serial number in square brackets e.g. [123456] Alternatively, the load cell can be selected in the drop down list from the load cell serial number and then by clicking the 'Formula' button to transfer it to the formula expression.

For example, to convert the data reading in Tonnes to read in Pounds the formula would be follows:

[111111]*2204.62

*The serial number of the load cell is shown in square brackets [111111]

To sum four load cells use:

[111111]+[123456]+[123411]+[123422]

The expression parser recognises the following symbols:

- + {Plus}
- {Minus}
- / {Divide}
- * {Multiply}
- () {Parenthesis}
- [xxxxxx] {Load cell serial number in square brackets}

Decimal numbers and some mathematical functions as follows :

- ABS: ABS(Value)
- CEILING: CEILING(Value)
- COS: COS(Value)
- COHS: COHS(Value)
- FLOOR: FLOOR(Value)
- LN: LN(Value)
- LOG: LOG(Value)
- ROUND: ROUND(Value)
- SIN: SIN(Value)
- SINH: SINH(Value)
- SQRT: SQRT(Value)
- TAN: TAN(Value)
- TANH: TANH(Value)

Examples of allowable formula

- [111111] + [234567]
- 2.5*[111111]
- [111111]+2.0
- (2*[111111])+100
- (2204.62*[111111])/100
- ([111111]*2)/([2*222222])
- FLOOR [111111]

Project Load Cells (contd.)

Description

Add descriptive information about the load cell ('Description' highlighted below) to help reference where it is being used in the actual lifting set-up. This description will be used to identify the load cell throughout the program and reports. The default for the description field will be created automatically as the load cell serial number.

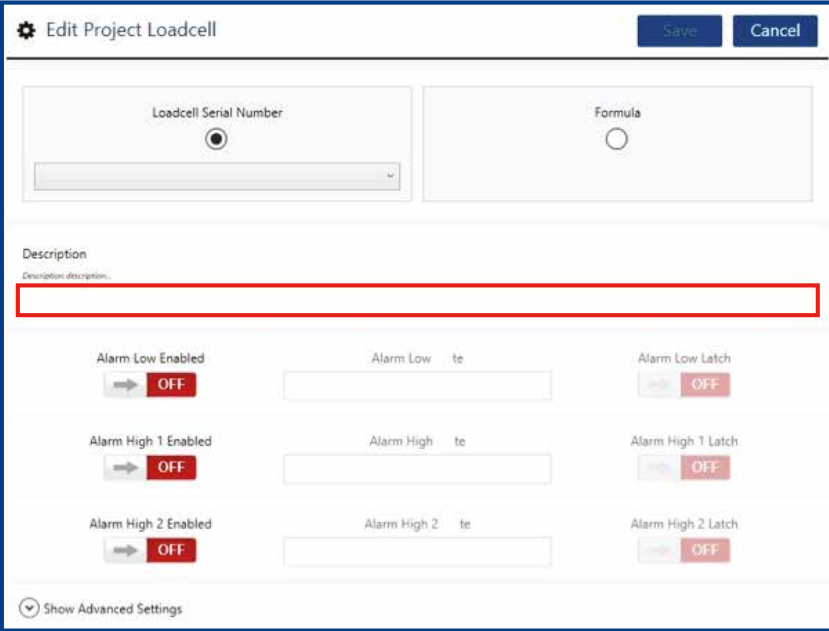

Please make sure you select the 'Save' button before moving onto other displays.

Alarm Settings



Three types of Alarm can be generated locally from the INSIGHT software:

- **Low**
The Alarm condition is met when the reading value goes below the entered 'Alarm Low' value.
- **Alarm High 1**
The Alarm condition is met when the reading value goes above the entered 'Alarm High' value. This alarm can be thought of as a Warning level.
- **Alarm High 2**
The Alarm condition is met when the reading value goes above the entered 'Alarm High 2' value. This alarm can be thought of as an Error level.

Project Load Cells (contd.)

To enable an alarm, click on any of the **'Low / High 1 / High 2 Enabled'** buttons to turn it on (green).

Enter the threshold value - above for **'Alarm High'**, or below for **'Alarm Low'** that you want the Alarm to activate on. This value will be in the units you have previously selected.

Finally, if you require the alarm to latch on, once the threshold has been reached, then click the **'Alarm Low / High 1 / High 2 Latch'** button.

These Alarms work individually on each load cell or formula. The number entered is an absolute value and not a percentage of WLL.

If the Alarm threshold is breached, the load cell display will show the Alarm in Red, and the PC speaker will beep.



For example, a Low Alarm has been set up and has crossed the threshold.

If the Alarm Latch is set and the threshold is passed, the alarm will continue even when the alarm condition goes back within the threshold.

To clear this click the **'Stop'** communications button available on the bottom right corner and then click **'Start'** to restart the display if required.

Advanced Settings

If you expand the **'Show Advanced Settings'** tab there are a range of further settings.

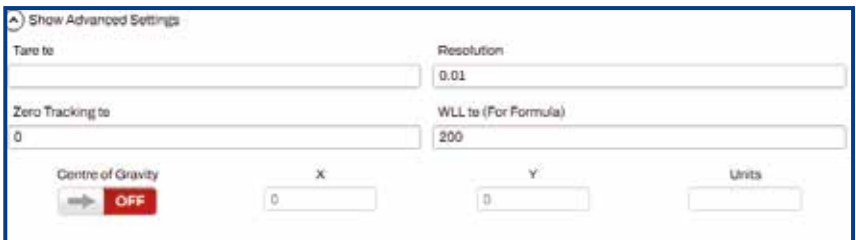

Project Load Cells (contd.)



- **Tare**

Enter a value here to compensate for the weight of shackles etc. This value will be subtracted from all readings Net or Gross.

- **Resolution**

This is read from the load cell and was set up when it was commissioned. It is based on the WLL and therefore it is unlikely that it/they will need to be changed. If displaying data from multiple load cells with different resolutions, then the resolution can be adjusted to align with other load cells. The Resolution defines the 'step' that data values take (for example if the resolution is 0.02) the data value could go from 1.02/1.04/1.06 etc.), and this automatically sets the number of decimal places which are displayed in the readings.

- **WLL (For Formula)**

This WLL is specifically for formula calculations and determines (along with the overload percentage) when the OVERLOAD text appears

- **Zero Tracking**

This is read from the load cell and was set up when it was commissioned. Consequently, it is unlikely it will need to be changed, but can be altered if required. Enter a value below which data readings will be displayed as zero.

- **Centre of Gravity**

Clicking on this option enables this load cell or formula to take part in '**Centre of Gravity**' calculations. Three further fields are associated with this.

- **X and Y co-ordinates**

Enter local X and Y co-ordinates of the load cell's position (relative to a locally defined 0,0 point or global co-ordinates) for the centre of gravity calculation: these can be in units of your choice - metres or feet etc.

- **Units**

Enter the units for the local X and Y co-ordinates as a text string such as metres.

Note: Tare, Zero Tracking and WLL will be in the units specified for the project.

If a formula is used to display data it should be noted that the individual load cells which make up the formula should also be displayed. This is to preserve the overload property of the system.

For example if you have two load cells A & B both with a WLL of 12te, but you are using them in tandem to arrive at formula of $[C]=[A]+[B]$ and then manually enter WLL for the [C] formula as 20te then clearly the individual load cells [A] or [B] with a WLL of 12te each could become overloaded and no warning would be generated, hence if the load cells [A]&[B] are also displayed their respective WLL will be checked and generate overload for each.

Please click the '**Save**' button to save all the settings related to the load cell into the project.

Load Cell Displays

Once you have set up the project and assigned the load cells required, the software will be able to display the load cell data readings for you to view.



You will then be presented with a matrix of the load cells and formula that you have included in the project.

An example of two load cells included in the project is shown below:

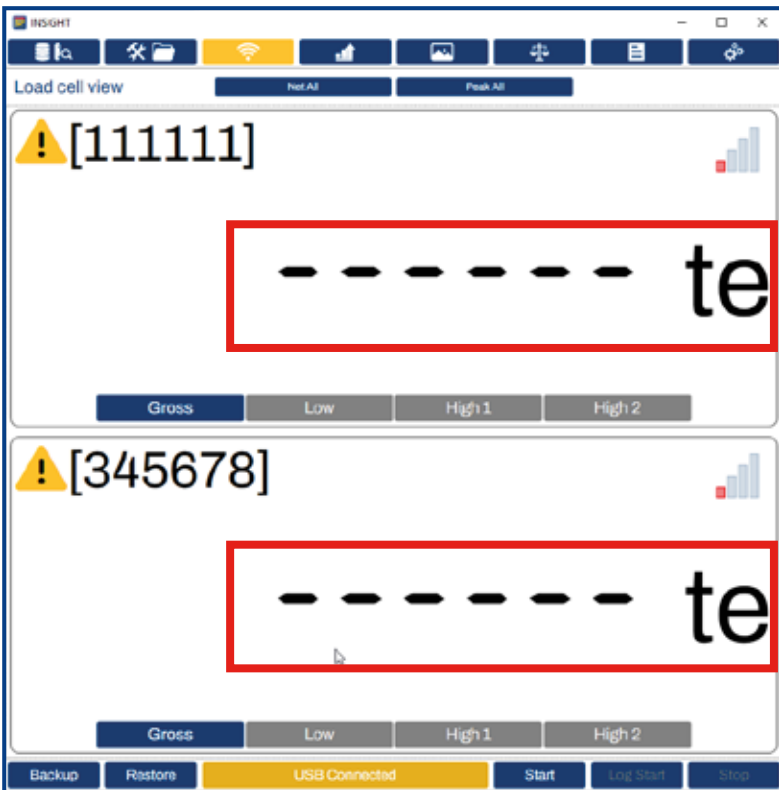

The display shows an individual entry for each of the load cells or formula. Each has a description, and also the data reading, which in this example is blank because the data readings capture process has not yet started (highlighted in the image above).

Please click the **'Start'** button at the bottom right corner to start the data reading capture process. The reading will then start showing instead of the blank screen. Existing projects can be selected from 'Projects' which is available on the project set-up page. The same procedure can be used to start the data capture process.

Load Cell Displays (contd.)

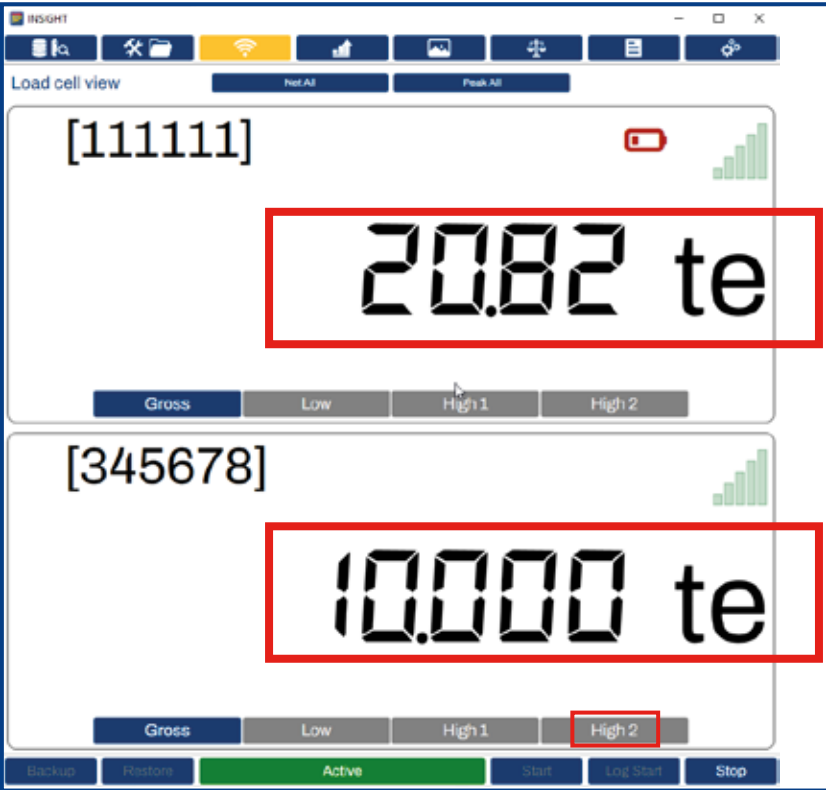

Gross

This screen shows a 'Gross' or 'Net' reading. Please click on this button to display one or the other.

Net

This screen shows a 'Gross' or 'Net' reading. Please click on this button to display one or the other.



Three possible alarms are shown, 'Low', 'High 1' and 'High 2'.

Load Cell Display Icons

Load cell warnings and errors will also be displayed for overload situations (shown as 'Overload'), load cell internal overload error (shown as 'LC error'), calibration due, and low battery.



RF Signal Level

The RF signal level is displayed as five bars, which will be filled in when the data readings are shown.



Load Cell Error

The load cell has exceeded its internal mV/V value. If this icon persists, the load cell needs to be returned to Crosby|Straightpoint.



Overload Error

The load cell has exceeded its WLL (Weight Load Limit) by more than 10%. It will need to be recalibrated since the strain gauge component could be damaged. This is a permanent error and will continue to show until the load cell is recalibrated.



Calibration Due Warning Error

Indicates it has been approximately a year since the connected load cell(s) has been calibrated by Crosby Straightpoint and will require recalibration.

This is a permanent error and will continue to show until the load cell(s) is recalibrated.

OVERLOAD

Overload Warning

This text replaces the displayed reading when the load cell value has exceeded the Overload Percentage field of the Project setup parameter.



Load Cell Low Battery

This is a transitory warning which will clear when the user inserts new batteries into their load cell.



Communication Error

Indicates INSIGHT has temporarily or permanently lost communication with a load cell. This could be due to the user clicking the STOP button or the batteries in the load cell failing or Insight losing contact with the load cell

Load Cell Charts



The main chart display shows this graph icon in the window, this graph is a constantly moving time line of the data at the current time.

There is a shadow graph at the bottom of the screen outlining the whole graphing period. This is overlaid with a rectangular shadow block, which represents a cursor. This shows the portion of the data being displayed in the current main graph. This cursor can be dragged to the left (using the mouse) to display data from a different time line in the main graph. It is most effective if the 'Stop' button is clicked, otherwise the display will revert to graphing the current time line.

- Clicking the lower Start button automatically activates the Record button to start data collection and charting.
- Click the chart 'Clear' to clear both graphs on the screen to restart the chart.
- Clicking the chart Stop button will stop data collection and charting.
- To expand or contract the horizontal scale on the time line, use the mouse scroll wheel.
- To view another position of the chart, click and hold the mouse cursor and drag it left or right.
- The 'Max History' field shows how many readings are stored before the buffer is overwritten (effectively the size of the graph shown).
- The recording 'Interval' is the interval over which to accumulate data readings and update the display.
- Click the check box beside the load cell description to remove that load cell from the graph.
- Click the Export button to generate a hard copy jpeg/png of the file.
- The size of the image can be adjust by altering via the export size option.

Visualisations

Visualisations allows the user to visualise the set-up and positioning of the load cell(s) with live data reading on screen with a picture background also being provided.



This is achieved by the user uploading an image of the set-up via the top right-hand corner 'Load Image' button (see icon on the left) and then dragging the load cell data reading boxes to their positions on screen.



Once this is done select the 'Save' button (see icon on the right) in the top right-hand corner.

Note:

- When 'Save' is selected it will automatically stop the data readings, which must be restarted after the save is performed.
- If no visualisation setup is done, all the load cells' data reading boxes will be arranged in the top left corner and show as a single data reading box.

The screenshot shows the Crosby Straightpoint software interface. At the top, there is a navigation bar with icons for database, tools, Wi-Fi, charts, image upload, scales, and settings. The main display area features a background image of a construction site. Three data boxes are overlaid on the image:

- [Loadcell 1]**: Shows a reading of 0.826 te. Below the reading are buttons for 'Gross', 'Low', 'High 1', and 'High 2'.
- [Loadcell 2]**: Shows a reading of 1.652 te. Below the reading are buttons for 'Gross', 'Low', 'High 1', and 'High 2'.
- [Loadcell 3]**: Shows a reading of 5.826 te. Below the reading are buttons for 'Gross', 'Low', 'High 1', and 'High 2'.

At the bottom of the interface, there is a status bar with buttons for 'Backup', 'Restore', 'Active', 'Start', 'Log Start', and 'Stop'.

Reports

The **'Report'** feature takes the current load cell display reading and exports it to a report file, either as plain text or an HTML format file.



When the **'Generate Report'** button is clicked, the software automatically generates a report file from a template and fills it with data from the project, including the project's name. It is then exported to the Report Output Directory, so that it can be viewed by the user.

This function also gives the user the flexibility to create their own report template files containing tokens to produce customised reports. To generate a report, the minimum that is required, is for the user to edit or create a template file and insert the serial number of their load cells.

The tokens which can be used in a plain text or html file are as follows:

Token	Evaluates to:
++PN++	Project Name
++DT++	Current Date as DD Month 2019
++TM++	Current Time as HH:MM:SS
++SD[xxxxxx]++	Description of Load Cell [xxxxxx]
++SV[xxxxxx]++	Current Data Value of Load Cell [xxxxxx]

An example of a tokenised plain text file would be as follows:

Project - ++PN++

Example Simple Text Report

Date: ++DT++

Time: ++TM++

<i>Load Cell</i>	<i>Description</i>	<i>Value</i>
<i>[123411]</i>	<i>++SD[123411]++</i>	<i>++SV[123411]++</i>
<i>[123422]</i>	<i>++SD[123422]++</i>	<i>++SV[123422]++</i>

This produces the output file

Project - project

Example Simple Text Report

Date: 29 April 2019

Time: 16:39:05

<i>Load Cell</i>	<i>Description</i>	<i>Value</i>
<i>[123411]</i>	<i>123411</i>	<i>23.36</i>
<i>[123422]</i>	<i>123422</i>	<i>20.80</i>

Reports (contd.)



Select which template you want to use from the report templates window (it will also list any templates that you have created using the provided tokens).

How to produce a report:

1. Browse to a directory containing the report template files shown below (these will be displayed in the available Report Templates window).



2. Browse to a directory to contain the output report.
3. Select the **'Start'** button in the lower right-hand corner of the screen to initiate a data reading capture.
4. With the cursor, highlight the template file you wish to use from the list within the **'Available Report Templates'** window.
5. Click the **'Generate Report'** button
6. The report will be generated, displayed and saved to the newly created page.

Centre of Gravity

The program has the ability to calculate the Centre of Gravity (CoG) of the load object, and produce a screen visualisation and report from this.

The coordinates entered are in units of your choice and are relative to a fixed point.

In order to use a load cell for a CoG project, the user must first specify the X and Y co-ordinates of its position in the 'Advanced Settings' section within the 'Edit Project' load cell menu. The CoG feature must be enabled, and the load cell's co-ordinates must be entered, along with the users' units of choice.



Once you have entered all the information for the CoG load cell, go to the CoG screen by clicking this option button in the menu bar.

Centre of Gravity (contd.)

Now enter the Job Details items and save it:

You can change the output folder to receive the report by using the 'Change Folder' option which defaults to c:\users\your-name\documents\insight\CoG reports

Likewise, you can enter the address details and a logo image to appear in the report under the Change Report option.

If it has not been started already, the data reading capture must be started by clicking the 'Start' button. The data values can also be displayed in the load cell display screen as well as the CoG screen if required.

The CoG screen should now be displaying the CoG position. The load cells which contribute to this CoG, appear as blue circles of size proportional to the weight of the load cells. The user can do Net All / Gross All using the available 'Net All' button.



The CoG is displayed in the centre with a cross through a circle, as shown here.

Centre of Gravity (contd.)



The CoG co-ordinates and weight are displayed with the CoG. Select the required number of recordings from the drop down menu. A maximum of 10 recordings can be done.

Once a position of stability has been achieved, readings for the report can be obtained.

To record the load values click the consecutive recording as 'Record 1', 'Record 2' up to 'Record N'. The 'Record' button will not be available, however, you can review the data reading taken, then reject and redo, if necessary.

To generate a report, please click the 'Generate Report' button (the html report will be generated) as shown below:



Crosby Straightpoint
WEIGHING RESULTS
Project

address1
address2
address3
address4
po9 1as

Date: Tuesday, 11 June 2024
 Operator: GRM
 Project: LP LR
 Project Number: AB1234
 Client: ACME Lifting

COG Units	Weight Units
MMETS	kg

Environmental Conditions

Temperature	Wind Speed	Wind Direction
15	2	SSC

Coordinates

Cell Position	Cell Description	X	Y
1	[11111]	1	1
2	[99999]	2	2
3	[345678]	3	1

Load Cell Input

Cell Position	Description	Weighting 1	Weighting 2	Weighting 3	Mean
1	[11111]	7.3	7.3	7.3	7.3
2	[99999]	9.8	9.8	9.8	9.8
3	[345678]	9.6	9.6	9.5	9.5
TOTALS		26.7	26.8	26.7	26.6

COG Result

	Weighting 1	Weighting 2	Weighting 3	Mean
COG X	2.08348	2.08428	2.0824	2.08263
COG Y	1.36659	1.36772	1.36904	1.36828

MEAN TOTAL WEIGHT (T): 26.7 Mean Centre of Gravity

Standard Deviation Weight: 0.05 COG X: 2.08263
 Standard Deviation in Percent: 0.19 COG Y: 1.36828

Notes:
 Notes1
 Notes2

Name	Signature	Date
Client Representative		
Customer Representative		

The generated report will be available in the COG Reports directory folder, the folder can be selected using 'View Reports' tab.

Proof Test Plus (PTP)



The Crosby Straightpoint INSIGHT Proof Testing Software package allows wireless monitoring at a safe distance of non-destructive load verification or proof testing. Test data is presented in the form of a Certificate of Testing and can be printed out from a browser directly as a PDF report or electronically transmitted/stored.

Typical applications include:

- Crane testing with water bags or block weights
- Pad eye or fly point testing
- Crash barrier testing
- Construction equipment testing, such as shoring columns, Acrow props and lintels
- Lifting and spreader beam
- Hydraulic cylinder load testing
- Lifting equipment testing, such as slings, chains, wire rope, hooks etc.

Features:

- User-friendly interface
- 100% wireless – eliminates problems caused by damaged cables
- 700m (2300 ft) range allows operation at safe distance from test
- Connects to any Crosby/Straightpoint TS range wireless load cell or load shackle
- Log data at speeds up to 200Hz
- Connects to any Crosby | Straightpoint wireless load cell or load shackle
- Automatically creates digitally signed pass or fail certificate
- Real time load v time graph display
- Free entry fields to note wind speed, sea states etc.

The Proof Test can be grouped into the following set of actions

- Create and Select the project containing the reference load cells.
- Enter the issuer details (normally once only)
- Select the reference load cells.
- Select or add the customer details.
- Enter the Test details
- Select or add the responsible engineer's details
- Perform the proof test
- Print the proof test report



CAUTION

Ensure Crosby Straightpoint wireless load cells are handled and used in accordance with the safety instructions within the appropriate Load cell User Manual. This is supplied with the load cell.

Other equipment used in conjunction with Crosby|Straightpoint load cells, such as jacks, hydraulic cylinders, chains, strops, lifting frames, and other material handling equipment, must be inspected, checked, handled and used in accordance the appropriate manufacturer/supplier information and/or with all pertinent regulatory requirements and industry standards/codes of practice.

Set-up

There are four groups of information required for the PTP certificate.

- Engineer Details Database
- Customer Details Database
- Issuer Details Database
- Test Details.

All but the Test Details can be entered individually through the front screen or as the proof test progresses.

Before starting the Proof Test use the Project Setup  option to select a project which contains the reference load cells you wish to use in the proof test. This project should also contain the units which you want the proof test to be in (i.e. te,lbs,kg,kN) .



If this is the first time the PTP section has been run you will be asked for the certificate issuer details as below.

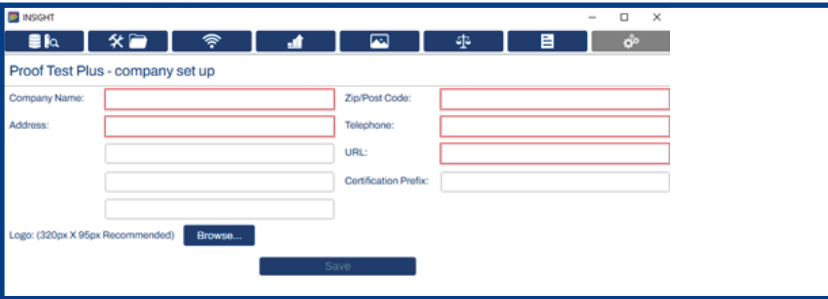

INSIGHT

Proof Test Plus - company set up

Company Name: Zip/Post Code:

Address: Telephone:

URL:

Certification Prefix:

Logo: (320px X 95px Recommended)

Fill in the details as appropriate and select save.

These details can be edited via the main PTP screen View/Edit Issuer Details option if required They will be printed on the certificate.



This setup process must be completed the first time while entering in to the PTP screen. Setup information is unique to each activation code. Carefully check all the information is correct before clicking 'Save' as this screen cannot be retrieved without re-activation.

Set up cont.

Proof Test Plus - company set up

Company Name:	Crosby Straightpoint	Zip/Post Code:	PO7 3DU
Address:	123 Proxima Park Houghton Ave Waterlooville Hampshire	Telephone:	02392 484491
		URL:	HPPTS://www.straightpoint.com
		Certification Prefix:	CRSP:

Logo: (320px X 95px Recommended) [Browse...](#)

Crosby | **SP**

[Cancel](#) [Save](#)

Backup Restore **USB Connected** Start Log Start Stop

When these issuer details are entered and saved the main PTP options menu will be displayed. This will now be the PTP entry point screen.

Backup Restore **USB Connected** Start Log Start Stop

New Proof Test View Existing Certificates

Add / View Customer Database Add / View Engineer Database

View / Edit Issuer Details

New Proof Test

Select 'New Proof Test' will take you through the whole process

NB. As stated previously, before starting the Proof Test use the Project Setup option  to select a project which contains the reference load cells you wish to use in the proof test.

This screen below allows the user to select the reference load cells to be used in the test by selecting up to two load cells from the project previously selected.

Clicking on the load cell selects it.

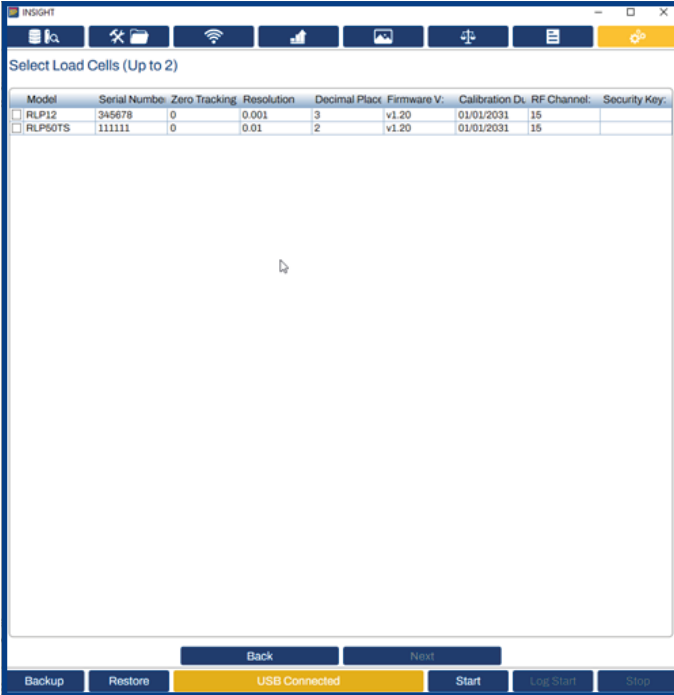

Note if your load cell is out of calibration a warning message will pop up and ask if you wish to continue, or rescan. If your load cell has recently been recalibrated it maybe that insight has not picked the new calibration date up and rescanning will fix the issue.

If the load cell/load shackle has not been recalibrated, a test can still be carried out but the final certificate will note that the test was performed using a load cell/load shackle out of the Crosby Straightpoint recommended calibration period.

Once the preferred load cells are selected click the next button to select or add the customer details on the following screen

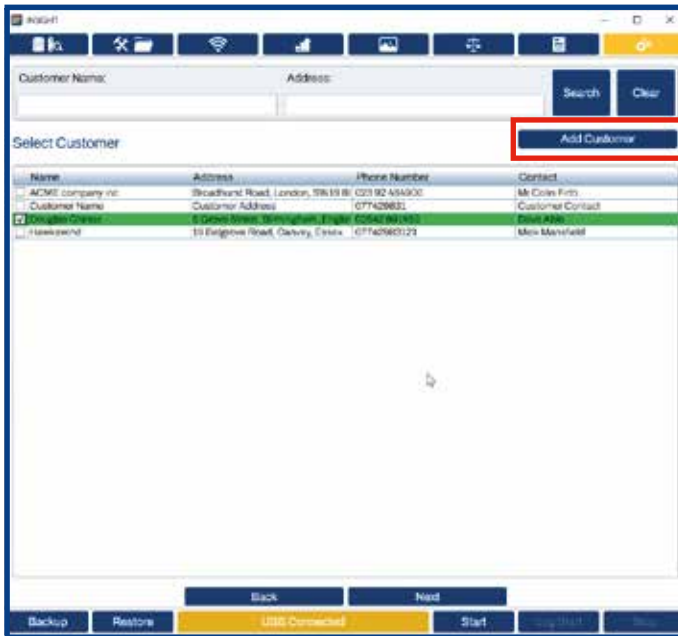

If the customer does not exist and a new one is required these details can be enter via the add customer button.

The customer details can also be entered via the front screen 'Add/View Customer Database' option.



Once the customer is selected click next to proceed to the screen to enter the test details.

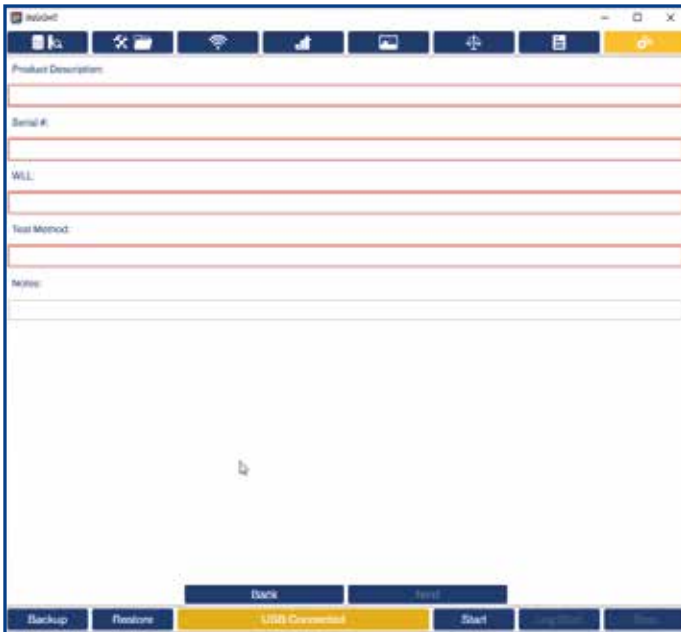

ASGHC

Product Description:

Serial #:

W/L:

Test Method:

Notes:

Back Next

Backup Restore USB Connected Start Log Out Stop

Enter the details which form the textual report items.

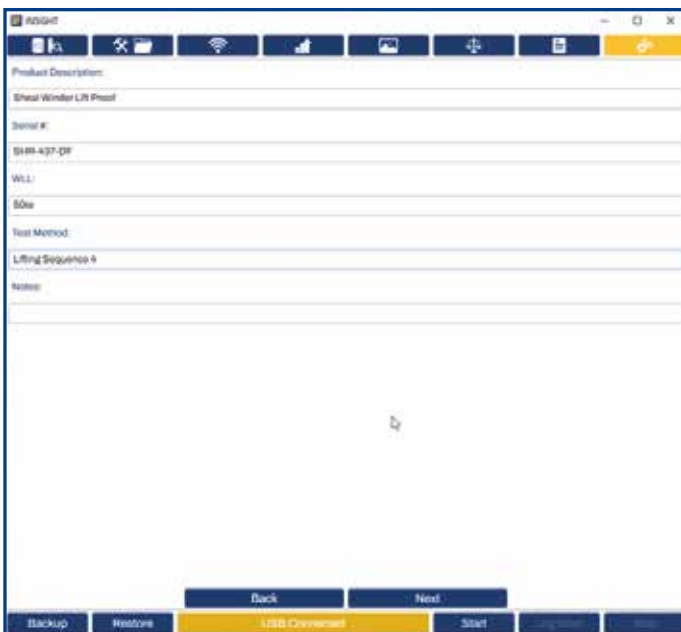

ASGHC

Product Description:

Shear Window LR Proof

Serial #:

SIR-A37-DF

W/L:

S06

Test Method:

Lifting Sequence 4

Notes:

Back Next

Backup Restore USB Connected Start Log Out Stop

Engineer details

Once the fields have been correctly entered, select the next button to progress to the next screen, here you can enter or add the responsible engineer details.

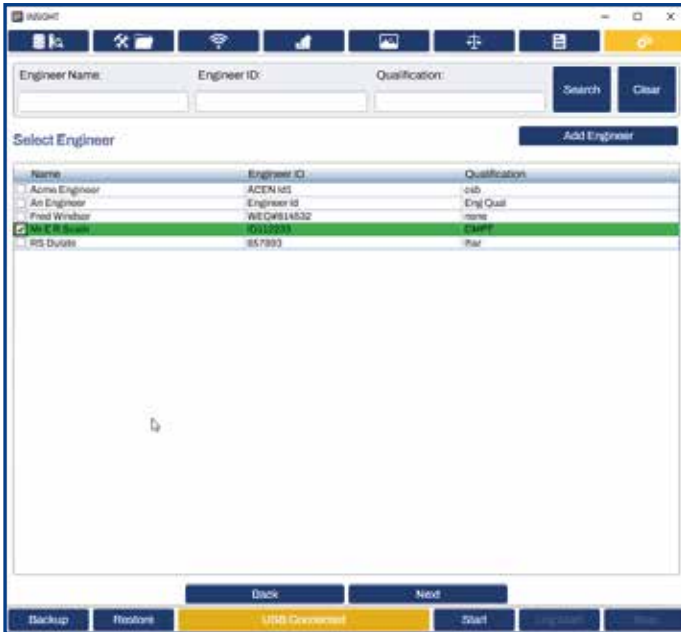

Once the engineer is added, select and click next to perform the proof test

Testing

To carry out a load verification or proof test, firstly, enter details of the scope of the test.



1. Enter the 'Load Test To' which is the load value the test is to be performed to. This is in the units of your choice from the project setting.

Then enter and the threshold percentage this defines the start point at which the software will begin to log the applied load (the point at which you will see the values on the graph) this defaults to 10% of the test load. E.g. if you have a 'load test to' of 50t and threshold of 10% the values will appear at 5t

2. Enter the Read Interval. This is set to 0.5 (seconds), or 2 times per second, by default, however, it may be adjusted up to 200 times per second.

3. Select the check box PEAK where required. In this mode, the live load reading and graph will hold and show the peak value attained during the test. Otherwise instant load values will be displayed.

4. Use the Net and Gross button to swap between these modes. Net will zero off the current load value.

5. Once all data is entered, click the Start button at the bottom of the screen.

The reading (highlighted below) will change to:

- **Black** – There is no communications between Insight and the load cell.
- **Amber** - to indicate that a successful connection has been established but that the value is below the threshold so the graph will not be displayed.
- **Green** - the value is above the threshold so the graph will be displayed and recorded.
- **Red** - the load value has exceeded the 'load test to' value calculated with the percentage overload which appears in the project setup page, this is normally 101%. Hence if the 'Load Test To' was 50t and the percentage in the project setup was 101% a read value would be displayed at 50.5t



The on-screen graph will now populate with data as the test progresses, and at the same time, the live read window will show a live spot load reading.

When the 'Load Test To' value has been reached the test is complete and the Stop or Save (Save will also Stop) button can be clicked.

If Stop has been clicked now click the Save button to move on to acceptance screen.

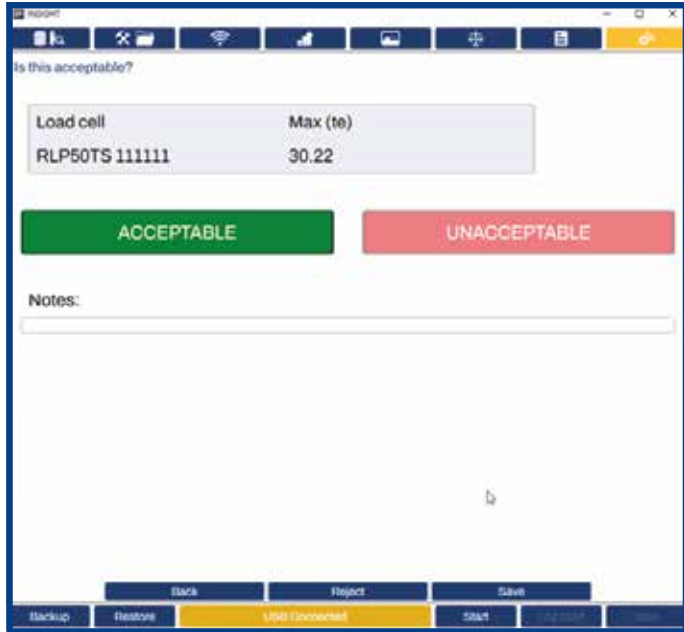

If the test has deemed to have failed for any reason then click the reject button to discard it and the test can be restarted.

If the test was performed correctly, a certificate can be generated. If the load test failed click on the Unacceptable button or if the test passed click the Acceptable button, then click the Save button to generate a certificate and end the test.

After the Save button is clicked the main PTP menu option screen will be displayed and it is then possible to select the 'View Existing Certificate' option to view and print the test report similar to the follow report .

View Existing Certificates

After completing the test and steps in the previous section, the system will return to the screen below:



1. Click [View Existing Certificates](#) This will reveal the screen below:

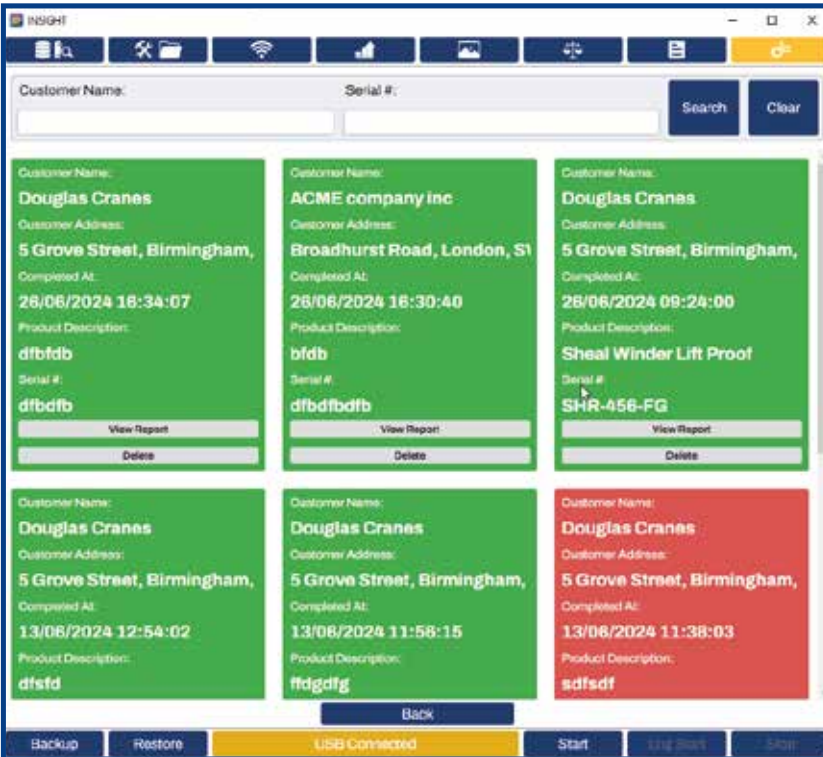

- Listings coloured **GREEN** are for tests that passed. Those coloured **RED** are those that failed.

Reports/Certificates may also be accessed using the search facility using the customer name or the serial number of the item tested.

- Click 'View Report' and the test certificate will appear on screen.
- To remove a Report/Certificate, click 'Delete' to reveal a pop-up that will ask for confirmation that the Report/Certificated is to be deleted.



The Report/Certificate may be saved, printed, emailed or exported to Microsoft Excel and other programs.

If the test was deemed **UNACCEPTABLE** the load test graph will not be displayed. The fail notes will be included instead.



Database options allow the user to pre-enter and manage entries, in the respective database, offline to avoid entering these details when running a live test.

Multiple entries are allowed for the Customer and Engineer databases.
It is possible to search these databases for specific entries and modify them.

To add a new entry - click Add Customer/Engineer then Save.

Add / Edit Customer Database



Add / Edit Engineer Database



Edit / View Issuer Database



The Issuer Database only has one entry, this is for the company issuing the Proof Test certificate.

Data Logging

While communication with the load cell(s) is in progress, you can start logging by clicking the **'Log Start'** (logging) button. When the **'Start'** button has been clicked and data is being read from the load cell, many of the standard menu options are not available. You will need to stop the scan or communication in order to be allowed access to menu items.

Logged Data File format

Logged data files are created and saved within the specified logging directory (defaults to c:\users\your_name\documents\insight\logs) with a file name which follows this format:

Insight.20YY-MM-DDTHH-MM-SS.csv

The file name format is independent of any regional date and time variations.

For example: **Insight.2019-04-25T10-48-38.csv** was created at 10am 48mins 38sec on 25th April 2024

The file format is saved as a standard comma separated variable (CSV), ready to read within a spreadsheet of your choice.

It has one header line, with the date and time, followed by the load cell serial number(s)

Example:

Date	Time	Elapsed Time (ms)	123411	333333
2019-07-02	11:31:53	5000	14.580	16.088
2019-07-02	11:31:58	10000	14.580	16.089
2019-07-02	11:32:03	15000	14.580	16.088
2019-07-02	11:32:08	20000	14.580	16.090
2019-07-02	11:32:13	25000	14.577	16.086
2019-07-02	11:32:18	30000	14.577	16.089
2019-07-02	11:32:23	35000	14.576	16.089
2019-07-02	11:32:28	40000	14.578	16.087

Elapsed Time is only relevant if the measurement/logging interval is less than 1 second

Backup and Restore Functions

INSIGHT has the ability to preserve the projects and settings using the backup and restore function.

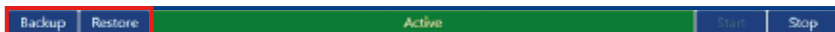

The backup function should only be used periodically, to guard against accidental project data deletions.

Select the **'Backup'** button in the lower left-hand corner to preserve INSIGHT data, this saves the state to a file called configuration.xml and defaults to the INSIGHT directory.

Projects and state can be restored at any time by use of the **'Restore'** button.

A secondary optional function of the **'Restore'** button, is to install ready-tailored projects and load cell details supplied by Crosby Straightpoint.

Glossary of Icons

This is a quick guide to explain what each icon refers to. They are in chronological order (as they appear within).



INSIGHT

Double click this icon to run the program.



Load Cell Database

Capture existing load cells into the data base.



RF Signal Level

Indicates load cell signal strength.



Project Settings

Click this to create and edit Project Settings.



Load Cell Charts

This graph is a constantly moving time line of the data at the current time.



Projects

List existing Projects.



Load image

Load a picture to form a backdrop for the data visualisations.



Alarm

The alarm threshold has been breached.



Save

Save a previously loaded picture (to form a backdrop for the data visualisations) so it will be automatically reloaded.



Load Cell Displays

This is to display load cell data readings.



Generate Report

When this button is clicked, the INSIGHT software automatically generates a report file.



Centre of Gravity

Click on this button to go to the **Centre of Gravity** screen.

Once there, select either the 'Gross' or 'Net' button.



Proof Test Plus Software (PTP)

Click on this button to go to the PTP screen.



This user guide has been compiled to cover the latest product description and specifications.

Crosby Straightpoint reserves the right to make changes to the contents herein without notice and shall not be responsible for any damages (including consequential) caused by reliance on the information provided, including but not limited to technical or editorial errors or omissions.

The only warranties for Crosby Straightpoint products and services are set forth in the warranty statements accompanying such products and services. Nothing herein should be construed as constituting an additional warranty.

© This user manual is the property of Crosby Straightpoint.

To make it easier in the event you need technical support customer service, please complete the following information:

Software Version:		
Media:	USB memory stick <input type="checkbox"/>	Download <input type="checkbox"/>
Date of Purchase:		

Trademarks

Windows® 7, Windows® 8, Windows® 10 and Windows® 11 are registered trademarks or trademarks of Microsoft Corporation in the United States and other countries.

Marks and Symbols



The following symbols may be used within this user guide.

Indicates a note or where attention is required.



IMPORTANT

Indicates an important step, instruction or information necessary for the proper functioning of the software or load cell monitoring.



CAUTION

Indicates a potentially hazardous situation that if not followed or avoided may result in personal injury or damage to property.

Contact Details

Crosby Straightpoint

123 Proxima Park
Houghton Avenue
Waterlooville, Hampshire
PO9 2NJ · UK

Tel: +44 (0)2392 484491

Crosby Straightpoint

2801 Dawson Road
Tulsa
OK 74110
USA

Tel: +1 (918) 834-4611

Notes

v3.00
Part No:
SU6045

Distributor Stamp



Crosby Straightpoint

123 Proxima Park, Houghton Avenue, Waterlooville, Hants, PO7 3DU UK · Tel: +44 (0)2392 484491
2801 Dawson Road, Tulsa, OK 74110 · USA · Tel: +1 (918) 834-4611